

# REDÜKTÖR DÜNYASI

— Güç Aktarma Sistemleri —

## REDÜKTÖR KATALOĞU -R SERİSİ-

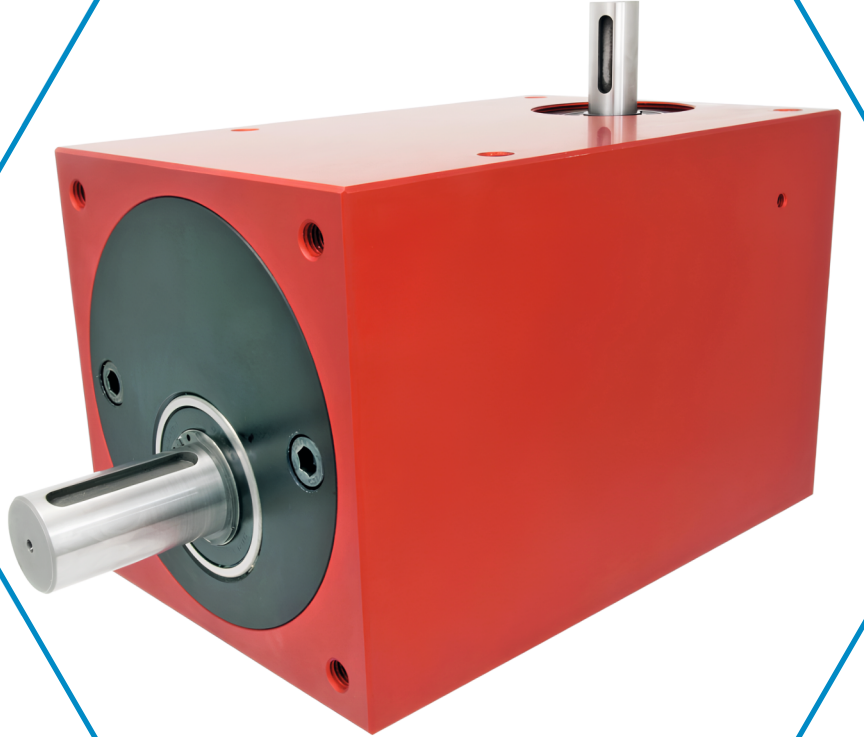
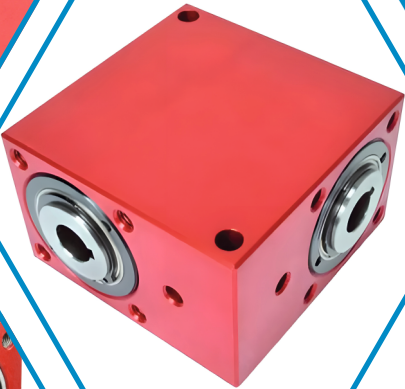
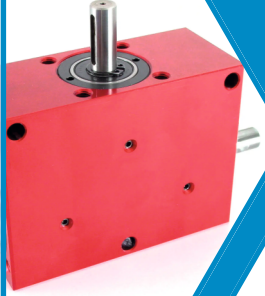
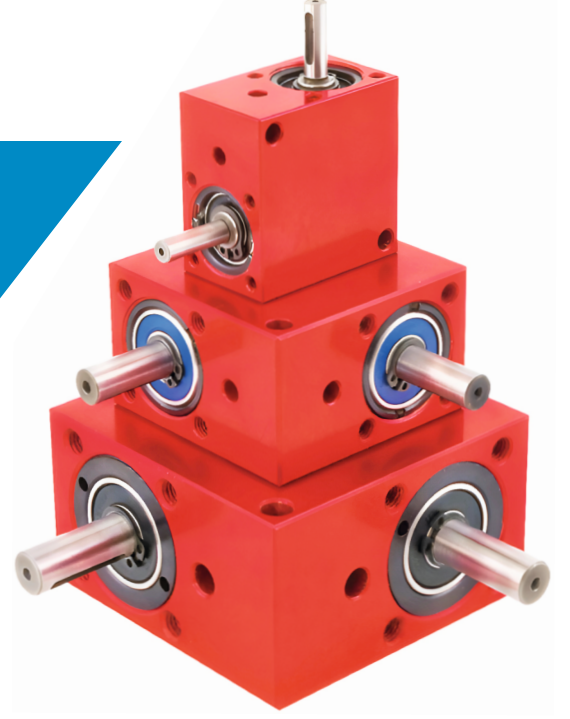

[www.reduktordunyasi.com.tr](http://www.reduktordunyasi.com.tr)

RA HR60

## YÖN DEĞİŞTİRİCİ REDÜKTÖRLER

RA HR60

### Ağır Hizmet Tipi Spiral Konik Dişli Redüktörler

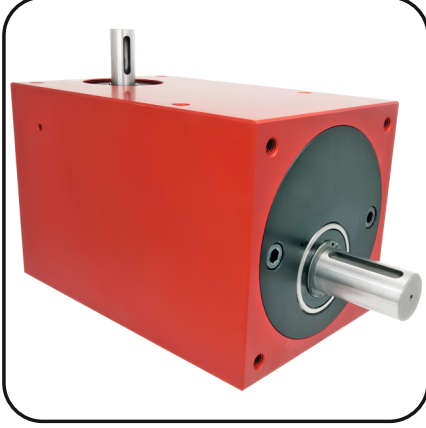

RA HR60

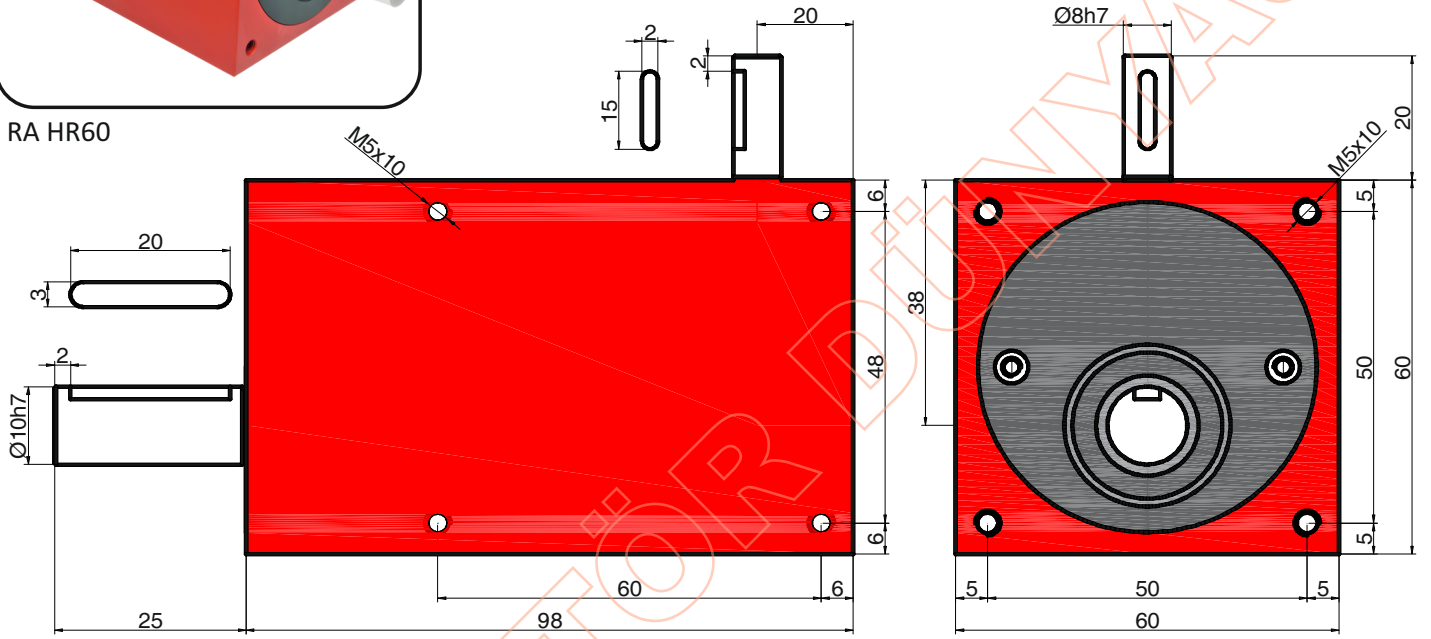

SİPARİŞ NUMARASI	ORAN	VERİM (1000 RPM)	ÇIKIŞ MOMENTİ Nm (1000 rpm)
RA HR60-6	6:1	88%	6
RA HR60-8	8:1	88%	6,4
RA HR60-10	10:1	88%	6,8
RA HR60-12	12:1	88%	7,2
RA HR60-16	16:1	88%	7,4
RA HR60-18	18:1	88%	7,6
RA HR60-20	20:1	88%	7,9
RA HR60-24	24:1	88%	8,1
RA HR60-30	30:1	88%	8,4

GÖVDE MALZEMESİ : ALUMİNYUM

AĞIRLIK :

KULLANILAN YAĞ : SHELL GADUS S2 V220 AD2.

#### ÇIKIŞ TORKU Nm

RPM DEVİR	REDÜKSİYON								
	6:1	8:1	10:1	12:1	16:1	18:1	20:1	24:1	30:1
3000	5	5,3	5,6	5,8	6	6,1	6,2	6,5	6,9
2000	5,3	5,6	5,9	6,3	6,5	6,8	6,9	7,2	7,5
1000	6	6,4	6,8	7,2	7,4	7,6	7,9	8,1	8,4
500	7,7	7,9	8,2	8,4	8,6	8,8	8,9	9,1	9,6
100	10	10,3	10,6	10,9	11,4	11,6	11,9	12,2	12,7
50	11,2	11,6	12	12,4	12,8	13,2	13,6	14	14,6
10	13	13,4	13,7	14	14,5	15	12,2	15,5	15,8



RA HR100

**YÖN DEĞİŞTİRİCİ REDÜKTÖRLER**

RA HR100

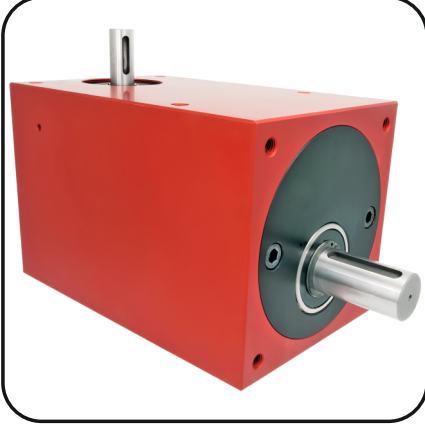
**Ağır Hizmet Tipi Spiral Konik Dişli Redüktörler**

RA HR100

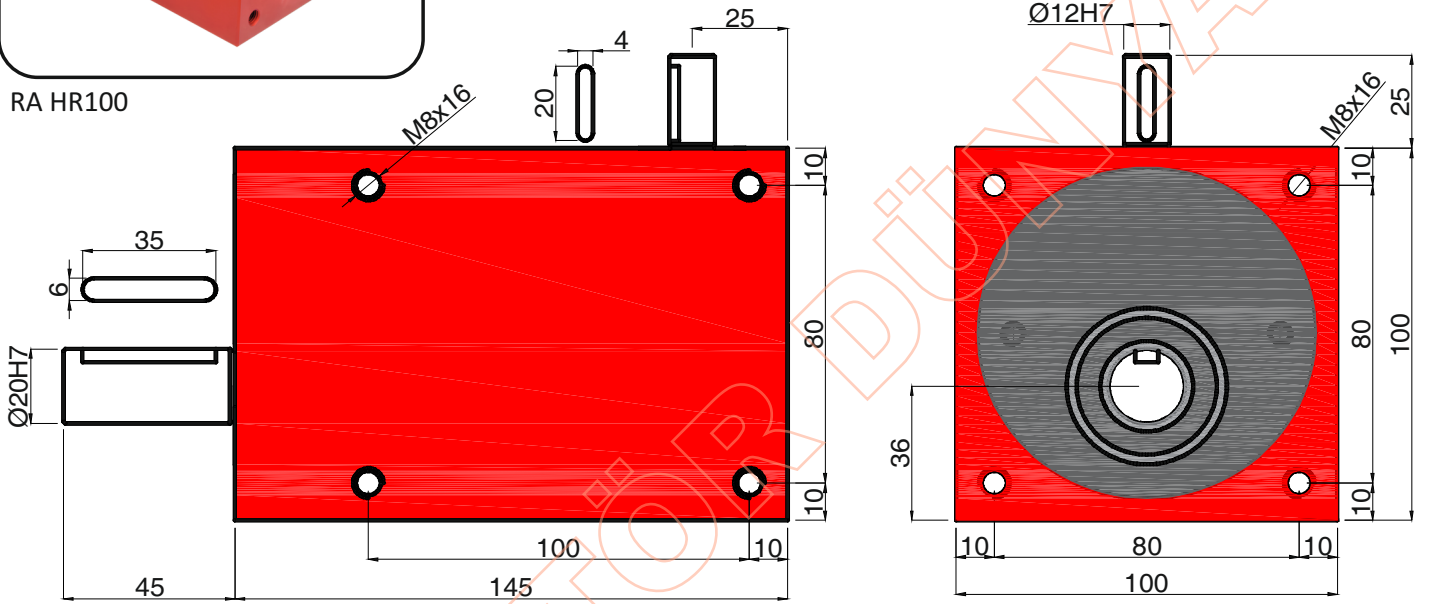

SİPARİŞ NUMARASI	ORAN	VERİM (1000 RPM)	ÇIKIŞ MOMENTİ Nm (1000 rpm)
RA HR100-6	6:1	88%	36
RA HR100-8	8:1	88%	37,5
RA HR100-10	10:1	88%	38
RA HR100-12	12:1	88%	39
RA HR100-16	16:1	88%	42
RA HR100-18	18:1	88%	43
RA HR100-20	20:1	88%	45
RA HR100-24	24:1	88%	47
RA HR100-30	30:1	88%	49

GÖVDE MALZEMESİ : ALUMİNYUM

AĞIRLIK :

KULLANILAN YAĞ : SHELL GADUS S2 V220 AD2.

**ÇIKIŞ TORKU Nm**

RPM DEVİR	REDÜKSİYON								
	6:1	8:1	10:1	12:1	16:1	18:1	20:1	24:1	30:1
3000	27	29	30	33	35	36	38	40	43
2000	32	35	38	41	44	48	51	54	59
1000	36	37,5	38	39	42	43	45	47	49
500	40	42	44	48	52	55	58	61	66
100	45	59	53	56	60	63	66	71	77
50	51	54	57	60	63	67	71	78	82
10	58	61	65	70	74	77	82	85	92

☎ 0212 485 8120

☎ 0532 442 1275

RA HR120

## YÖN DEĞİŞTİRİCİ REDÜKTÖRLER

RA HR120

### Ağır Hizmet Tipi Spiral Konik Dişli Redüktörler

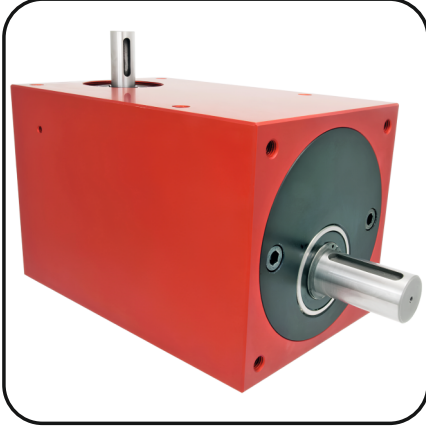

RA HR120

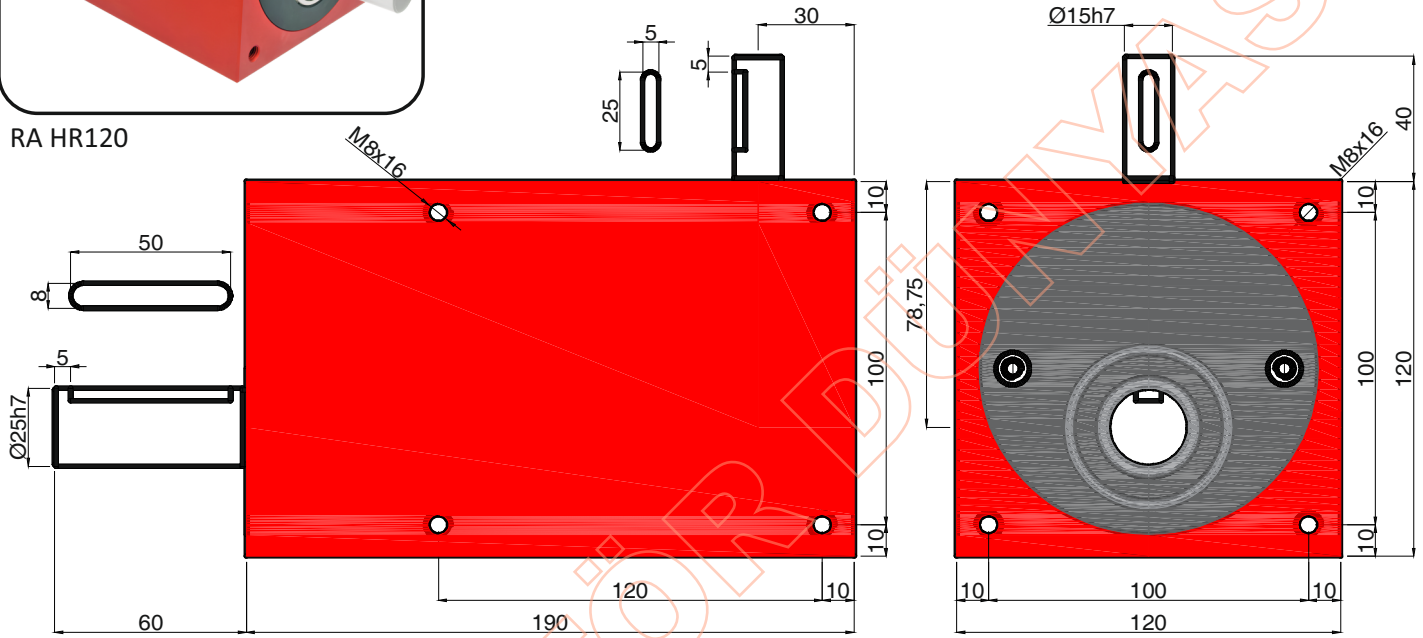

SİPARİŞ NUMARASI	ORAN	VERİM (1000 RPM)	ÇIKIŞ MOMENTİ Nm (1000 rpm)
RA HR120-6	6:1	88%	51
RA HR120-8	8:1	88%	52
RA HR120-10	10:1	88%	53
RA HR120-12	12:1	88%	54
RA HR120-16	16:1	88%	56
RA HR120-18	18:1	88%	57,5
RA HR120-20	20:1	88%	58
RA HR120-24	24:1	88%	60
RA HR120-30	30:1	88%	62

GÖVDE MALZEMESİ : ALUMİNYUM

AĞIRLIK :

KULLANILAN YAĞ : SHELL GADUS S2 V220 AD2.

#### ÇIKIŞ TORKU Nm

RPM DEVİR	REDÜKSİYON								
	6:1	8:1	10:1	12:1	16:1	18:1	20:1	24:1	30:1
3000	40,6	41,5	42	42,5	44,5	46	48	49,1	51
2000	45	45,5	46,5	47,3	48,5	50,7	52	53	54
1000	51	52	53	54	56	57,5	58	60	62
500	60,3	61	62	62,8	64	65,8	67	68,4	70
100	77	78	80	83,1	85	87	89	91	94
50	85	87	88	90,7	94	95,6	98	101	105
10	102	104	105	106	107	108,3	109	110	115

RA HR160

## YÖN DEĞİŞTİRİCİ REDÜKTÖRLER

RA HR160

### Ağır Hizmet Tipi Spiral Konik Dişli Redüktörler

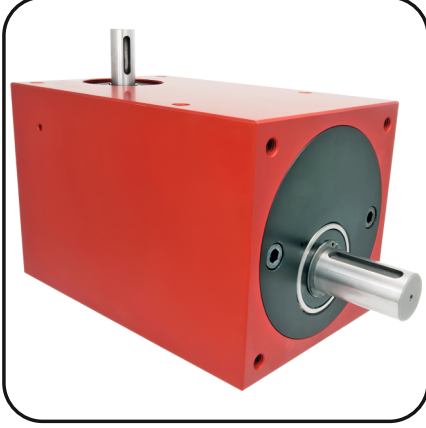

RA HR160

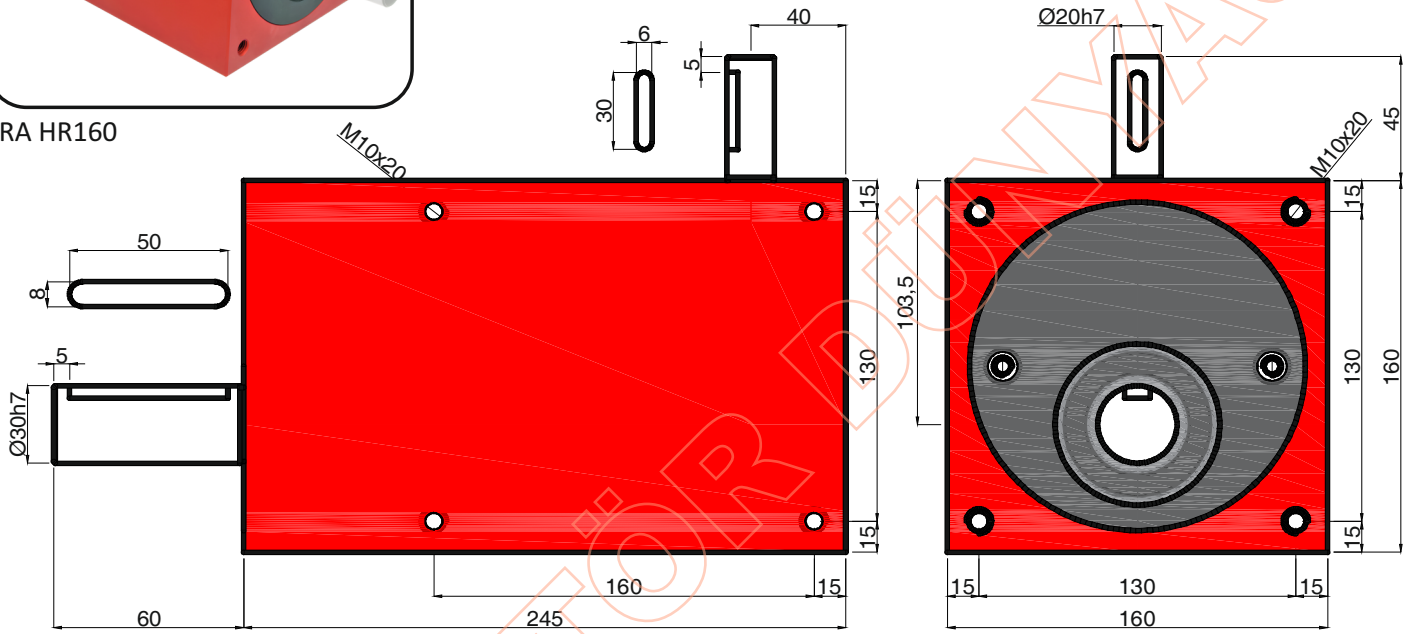

SİPARİŞ NUMARASI	ORAN	VERİM (1000 RPM)	ÇIKIŞ MOMENTİ Nm (1000 rpm)
RA HR160-6	6:1	88%	105
RA HR160-8	8:1	88%	108
RA HR160-10	10:1	88%	112
RA HR160-12	12:1	88%	115
RA HR160-16	16:1	88%	121
RA HR160-18	18:1	88%	127
RA HR160-20	20:1	88%	134
RA HR160-24	24:1	88%	140
RA HR160-30	30:1	88%	148

GÖVDE MALZEMESİ : ALUMİNYUM

AĞIRLIK :

KULLANILAN YAĞ : SHELL GADUS S2 V220 AD2.

#### ÇIKIŞ TORKU Nm

RPM DEVİR	REDÜKSİYON								
	6:1	8:1	10:1	12:1	16:1	18:1	20:1	24:1	30:1
3000	86	88	90	92	95	98	101	105	108
2000	91	94	97	100	105	109	114	120	128
1000	105	108	112	115	121	127	134	140	148
500	126	129	134	138	141	145	148	152	157
100	162	166	171	176	181	184	189	190	198
50	180	186	193	199	203	205	208	210	214
10	215	220	230	238	244	250	260	270	280

☎ 0212 485 8120

☎ 0532 442 1275

RA HR200

## YÖN DEĞİŞTİRİCİ REDÜKTÖRLER

RA HR200

### Ağır Hizmet Tipi Spiral Konik Dişli Redüktörler

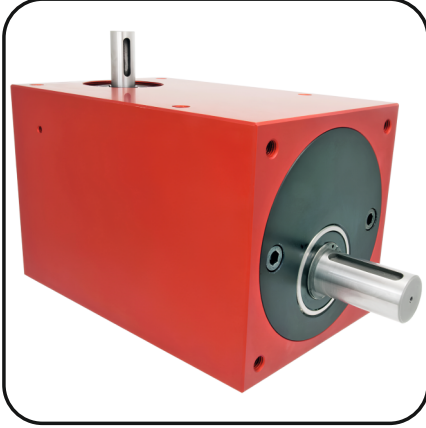

RA HR200

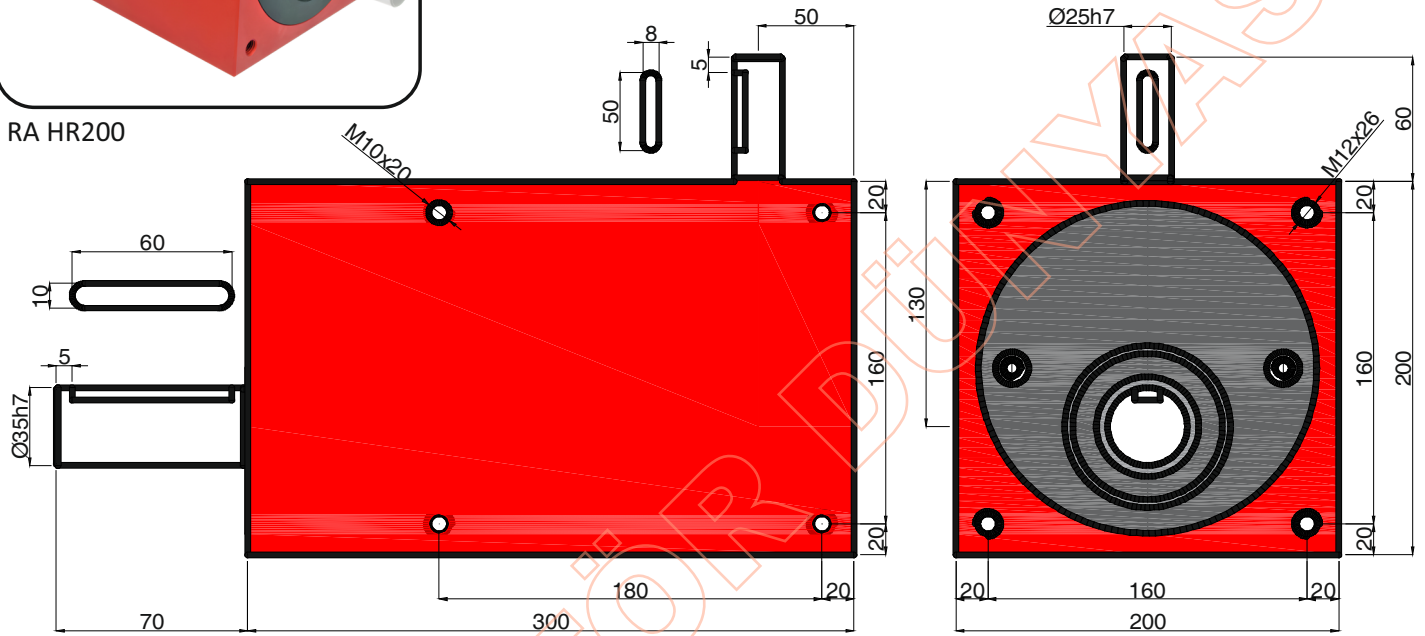

SİPARİŞ NUMARASI	ORAN	VERİM (1000 RPM)	ÇIKIŞ MOMENTİ Nm (1000 rpm)
RA HR200-6	6:1	88%	240
RA HR200-8	8:1	88%	240
RA HR200-10	10:1	88%	240
RA HR200-12	12:1	88%	240
RA HR200-16	16:1	88%	240
RA HR200-18	18:1	88%	240
RA HR200-20	20:1	88%	240
RA HR200-24	24:1	88%	240
RA HR200-30	30:1	88%	240

GÖVDE MALZEMESİ : ALUMİNYUM

AĞIRLIK :

KULLANILAN YAĞ : SHELL GADUS S2 V220 AD2.

#### ÇIKIŞ TORKU Nm

RPM DEVİR	REDÜKSİYON								
	6:1	8:1	10:1	12:1	16:1	18:1	20:1	24:1	30:1
3000	-	-	-	-	-	-	-	-	-
2000	215	215	215	215	215	215	215	215	215
1000	240	240	240	240	240	240	240	240	240
500	270	270	270	270	270	270	270	270	270
100	310	310	310	310	310	310	310	310	310
50	400	400	400	400	400	400	400	400	400
10	450	450	450	450	450	450	450	450	450

## Referanslarımızdan bazıları...



Elektrik Üretim Anonim A.Ş.

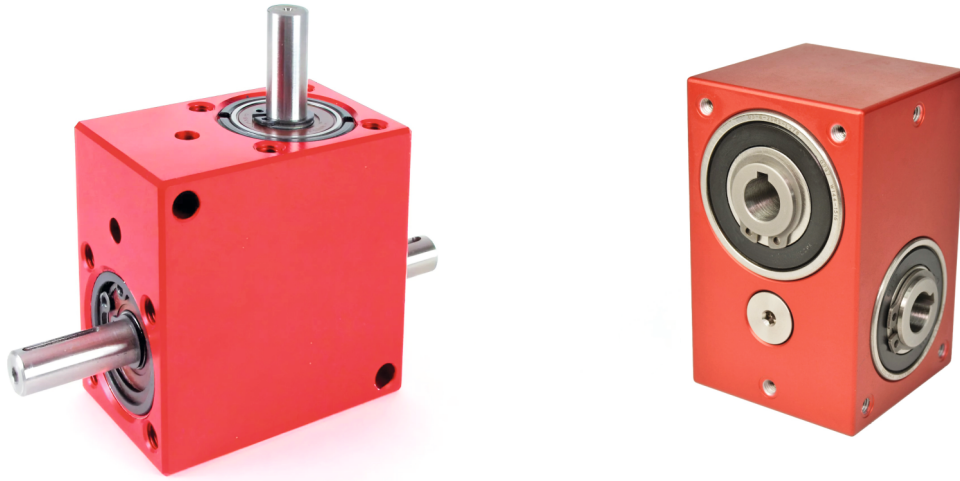

## REDÜKTÖR DÜNYASI

— Güç Aktarma Sistemleri —

Endüstriyel Teknik Teknolojiler Makine Ekipmanları San. Tic. Ltd. Şti.

🏠 Rami Kışla Cad. Gündoğar 1 İş Merkezi NO: 68/71 Topçular Eyüpsultan / İSTANBUL

☎ : 0 212 485 81 20

☎ : 0 212 493 30 21

📞 : 0 532 442 1 275

✉ : info@reduktordunyasi.com.tr

🌐 : www.reduktordunyasi.com.tr

📷 reduktordunyasi [in](#) reduktordunyasi [f](#) reduktordunyasi [p](#) reduktordunyasi